

## 6500-15

**Angle de pas**  
**Schrittwinkel**  
**Step angle** 1.8 °

**Diamètre**  
**Durchmesser**  
**Diameter** 57.2 mm

**Poids**  
**Gewicht**  
**Weight** 360 g

**Couple de retenue**  
**Haltemoment** 320/230 mNm  
**Holding torque**

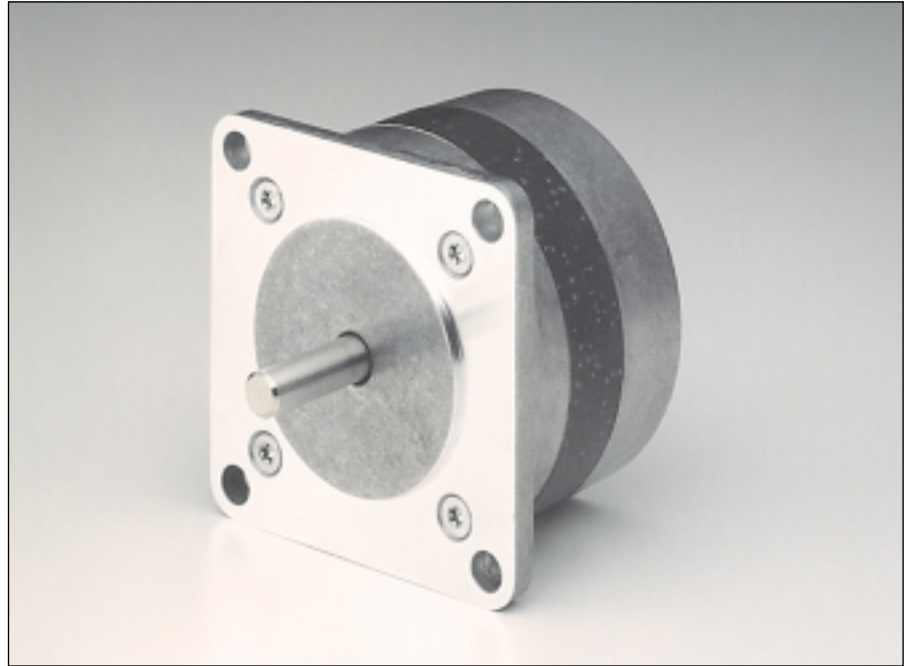

		Résistance de phase Phasenwiderstand Phase resistance $\Omega$	Induct. de phase Phaseninduktivität Phase inductance mH	Courant de phase Phasenstrom Phase current A	Couple de retenue Haltemoment Holding torque mNm	Puissance nominale Nennleistung Nominal power W	
<b>bipolar</b>	<b>6500-15-2-1.6</b>	1.6	3.85	1.5	320	7.2	
	<b>6500-15-4-1.6</b>	1.6	1.75	1.5	250	7.2	
<b>unipolar</b>	<b>6500-15-4-13.5</b>	13.5	12.3	0.5	230	6.75	

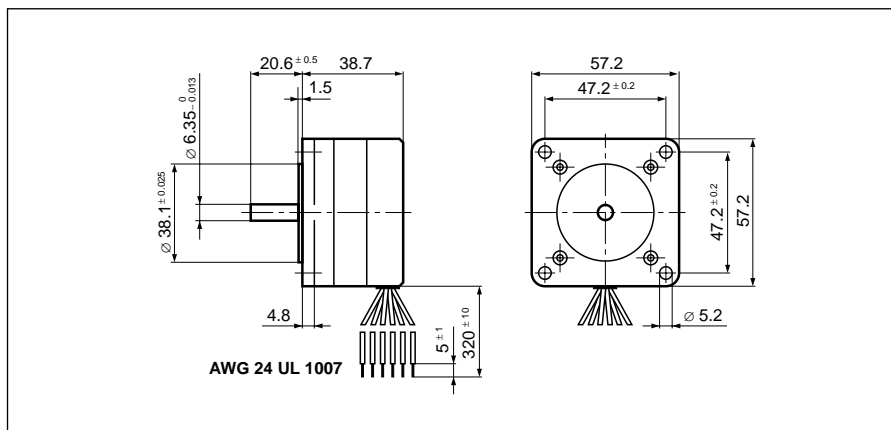

Pas/ Schritte/U Steps/rev	<b>200</b>
Précision/pas Schrittgenauigkeit Step accuracy	<b>± 5 %</b>
Inertie du rotor Rotorträgheitsmoment Rotor inertia	<b>77 gcm<sup>2</sup></b>
Classe d'isolation Isolationsklasse Insulation class	<b>B 130 °C</b>
Protection Schutzart Protection	<b>DIN 40050 IP 30</b>
Tension d'essai Prüfspannung Test voltage	<b>500 VAC</b>
Couple résiduel Restmoment Detent torque	<b>23 mNm</b>

**Caractéristiques dynamiques**  
**Dynamische Daten**  
**Dynamic characteristics**

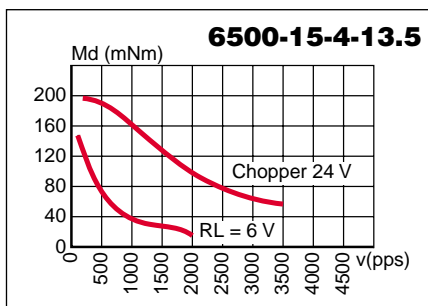
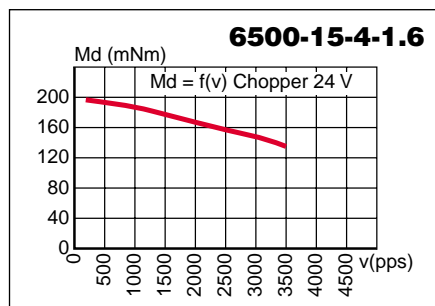
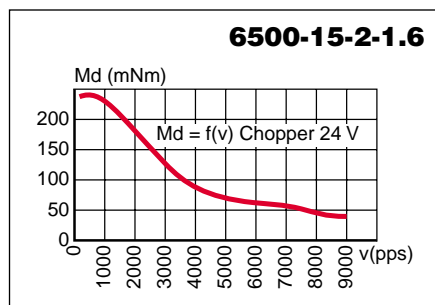

**Caractéristiques statiques**  
**Statische Daten**  
**Static characteristics**

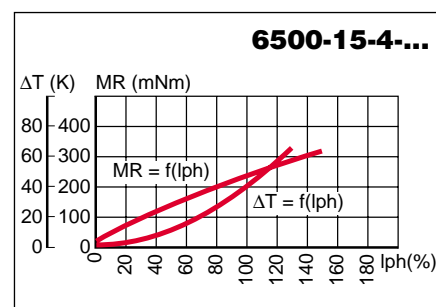
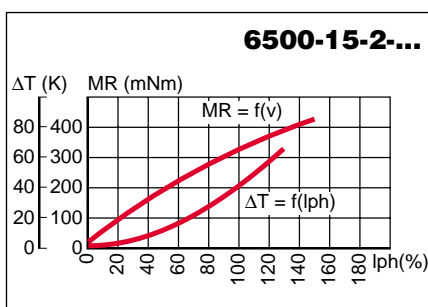

Possibilités d'exécutions adaptées sur demande.  
 Auf Wunsch werden kundenspezifische Anforderungen berücksichtigt.  
 Special requirements can be made to customer specification.

**SONCEBOZ SA**  
 CH-2605 Sonceboz  
 Tél: +41 32 488 11 11  
 Fax: +41 32 488 11 00  
 E-Mail: info@sonceboz.com  
 Internet: www.sonceboz.com

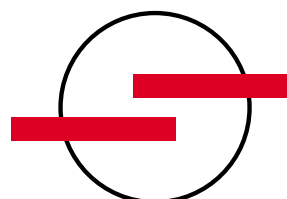

**SONCEBOZ**  
 The driving force